

PRODUCT DATA SHEET

LIGHTNING PROTECTION AND EARTHING SYSTEM COMPONENTS

Code: 61 01 100

ed.03/2021

Description: Ø8–10 mm St/tZn conductor fastener

Page 1 of 2

Application

Fastening round or stranded conductor. Used in air termination system, down conductor system. Suitable for brick or concrete surfaces.

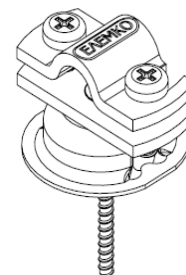

Classification as per IEC EN 62561

- Metallic.
- With screws.
- Designed to clamp but allow axial movement of the conductor.

Technical characteristics

Material	Hot dip galvanized steel (St/tZn)
Screws	M6x16 mm, V2A stainless steel screws One electroplated zinc steel wood fixing screw
Withstands (according to IEC EN 62561-4)	Lateral load, 200 N Axial load, 50 N

Installation instructions

Conductor's dimensions	Ø8–10 mm (50–70 mm ²)
Compatibility with conductors made of	Al, SSt (Stainless Steel), St/tZn
Tightening torque of conductor	3,5Nm
Fixing on brick or concrete	Through a wood fixing screw (included) and a PVC wall plug Ø8 mm (not included)
Spacing between fasteners of air termination conductors	≤1000 mm for solid conductor ¹⁾ . ≤500 mm for stranded conductor ¹⁾ .
Spacing between fasteners of down conductors	≤1000 mm for solid conductor. ≤1000 mm for stranded conductor used for heights ≤20 m. ≤500 mm for stranded conductor for heights ≥20 m.
Before and after of change of direction or clamp or contraction-expansion absorbing component.	≤300 mm.

Testing as per IEC EN 62561

The component has successfully passed the testing requirements of standard IEC EN 62561-4 "Lightning protection system components (LPSC) – Part 4 : Requirements for conductor fasteners".
Test report No **31388** by accredited laboratory as per ISO 17025

Manufacturing Quality Control

Manufacturing quality control according standard ISO 9001

Country of Origin

Greece

Optional accessories²⁾

PVC sealing washer, ELEMKO code 61 03 201

Unit: piece / Package: 50 pieces

See below typical application of the fastener

¹⁾ Where additional mechanical strength is required, e.g snow, strong winds etc, the spacing between the fasteners should be ≤300 mm.

²⁾ See relevant data sheet

We reserve the right to introduce changes in the component due to technical evolution.

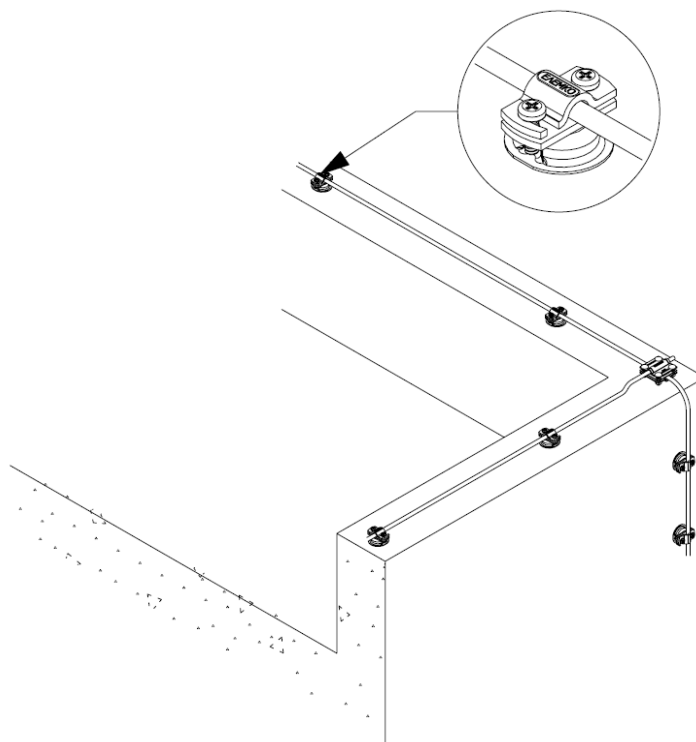
PRODUCT DATA SHEET**LIGHTNING PROTECTION AND EARTHING SYSTEM COMPONENTS****Code: 61 01 100****ed.03/2021****Description: Ø8-10 mm St/tZn conductor fastener****Page 2 of 2**

Typical application of the fastener