

## PRODUCT DATA SHEET

### LIGHTNING PROTECTION AND EARTHING SYSTEM COMPONENTS

**Code: 62 08 117**

ed.02/2021

**Description: St/tZn round or stranded conductor to rod connector with stainless steel bolts**

#### Application

Clamp, for connecting solid round or stranded conductor to air termination rod, earth lead-in rod, earth rod. Used in air termination system, down conductor system, earthing system.

#### Classification as per IEC EN 62561

- Heavy duty (H – 100 kA)
- General use
- Intended to withstand a static mechanical load
- Non-permanent connection

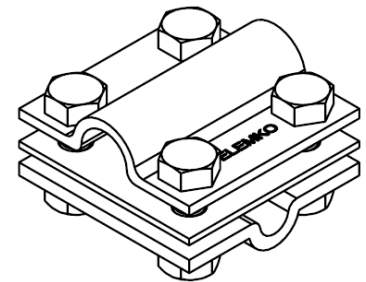

#### Technical characteristics

Material	Hot dip galvanized steel (St/tZn)
Description	Is consisted of two external plates with dimensions 60x60 mm and one intermediate plate.
Bolts / nuts	M8x30 mm, V2A stainless steel hexagon head bolts M8 V2A stainless steel nuts

#### Installation instructions

Conductor's dimensions	Ø8–10 mm (50–70 mm <sup>2</sup> )
Rod's dimensions	Ø16 mm
Connection arrangements	Cross (B1) Parallel (B2)
Installation	Above ground, buried in ground, embedded in concrete
Can be connected above ground with	Al, Stainless Steel (SSt), St/tZn
Can be connected buried in ground with	Stainless Steel (SSt), St/tZn
Can be connected in concrete with	Cu, Cu/eSn, Stainless Steel (SSt), St/tZn
Tightening torque	13 Nm

#### Testing as per IEC EN 62561

The component has successfully passed the testing requirements of standard IEC EN 62561-1 "Lightning protection system components (LPSC) – Part 1 : Requirements for connection components".

Test report No **30990** by accredited laboratory as per ISO 17025

#### Manufacturing Quality Control

Manufacturing quality control according standard ISO 9001

#### Country of Origin

Greece

**Unit: piece / Package: 20 pieces**

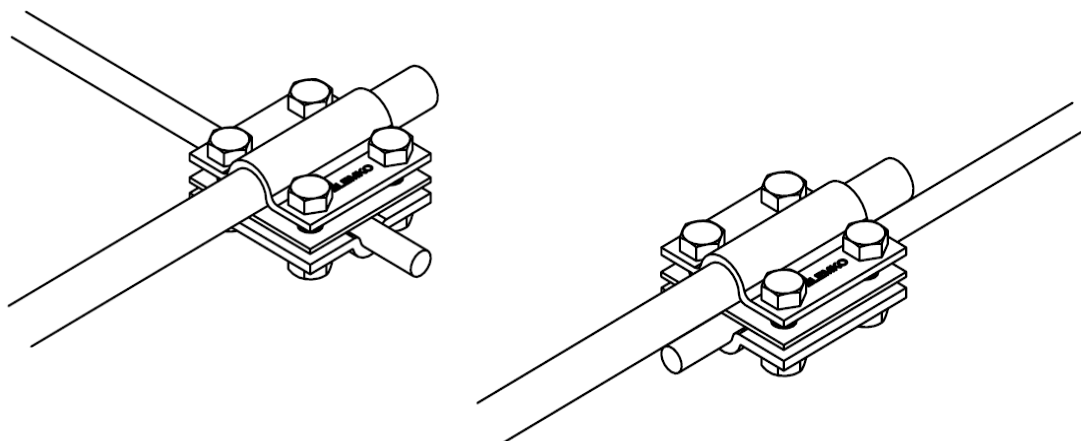

We reserve the right to introduce changes in the component due to technical evolution.