

PRODUCT DATA SHEET

LIGHTNING PROTECTION AND EARTHING SYSTEM COMPONENTS

Code: 62 21 835

Description: Cu conductor connection clamp

ed.02/2021

Application

Clamp, for connecting solid round or stranded conductor to tape conductor. Used in air termination system, down conductor system, earthing system.

Classification as per IEC EN 62561

- Heavy duty (H – 100 kA)
- General use
- Intended to withstand a static mechanical load
- Non-permanent connection

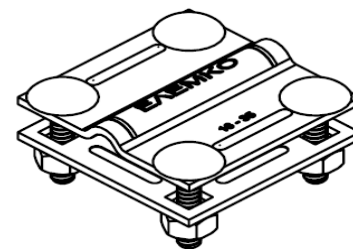

Technical characteristics

Material	Copper (Cu)
Description	Is consisted of two plates with dimensions 50x50 mm.
Bolts / nuts	M6x25 mm, V2A stainless steel carriage bolts M6 V2A stainless steel nuts

Installation instructions

Conductor's dimensions	16–35 mm ²
Tape's dimensions	Up to 30 mm width and 5 mm thickness
Connection arrangements	Cross (B1) Parallel (B2)
Installation	Above ground, buried in ground, embedded in concrete
Can be connected above ground with	Cu, Cu/eSn, SSt (Stainless Steel), St/eCu
Can be connected buried in ground with	Cu, Cu/eSn, SSt (Stainless Steel), St/eCu
Can be connected in concrete with	Cu, Cu/eSn, SSt (Stainless Steel), St/eCu, St/tZn
Tightening torque	9 Nm

Testing as per IEC EN 62561

The component has successfully passed the testing requirements of standard IEC EN 62561-1 "Lightning protection system components (LPSC) – Part 1 : Requirements for connection components".
Test report No **30786** by accredited laboratory as per ISO 17025

Manufacturing Quality Control

Manufacturing quality control according standard ISO 9001

Country of Origin

Greece

Unit: piece / Package: 25 pieces

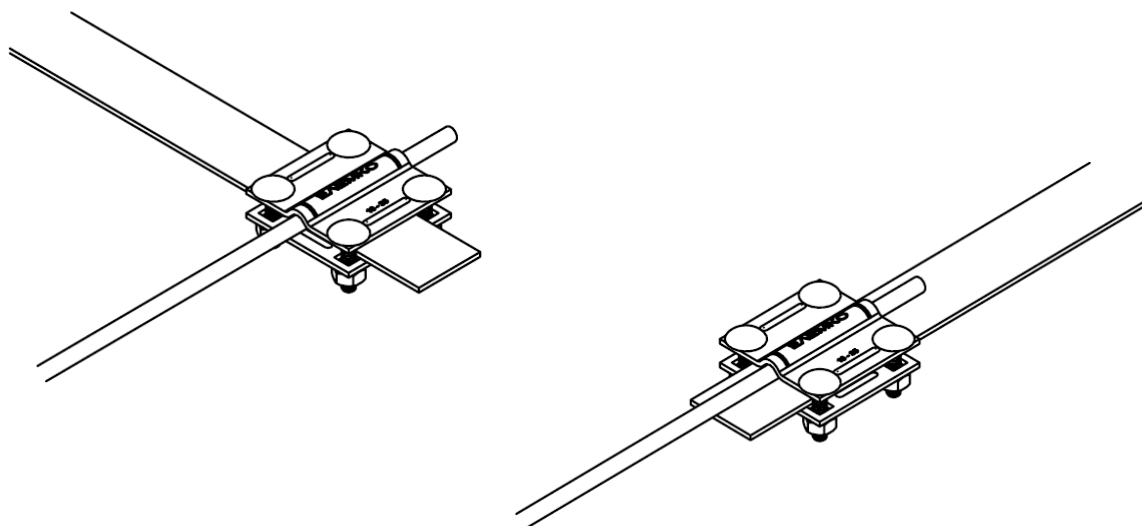

We reserve the right to introduce changes in the component due to technical evolution.