

## PRODUCT DATA SHEET

### LIGHTNING PROTECTION AND EARTHING SYSTEM COMPONENTS

**Code: 62 21 836**

**Description: Cu conductor connection clamp**

ed.02/2021

#### Application

Clamp, for connecting solid round or stranded conductors. Used in air termination system, down conductor system, earthing system.

#### Classification as per IEC EN 62561

- Heavy duty (H – 100 kA)
- General use
- Intended to withstand a static mechanical load
- Non-permanent connection

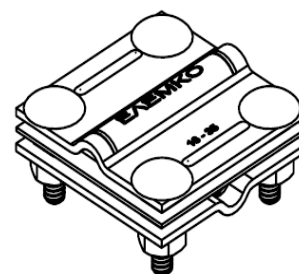

#### Technical characteristics

Material	Copper (Cu)
Description	Is consisted of two external plates with dimensions 50x50 mm and one intermediate plate.
Bolts / nuts	M6x25 mm, V2A stainless steel carriage bolts M6 V2A stainless steel nuts

#### Installation instructions

Conductor's dimensions	16–35 mm <sup>2</sup>
Connection arrangements	Cross (B1) Parallel (B2)
Installation	Above ground, buried in ground, embedded in concrete
Can be connected above ground with	Cu, Cu/eSn, SSt (Stainless Steel), St/eCu
Can be connected buried in ground with	Cu, Cu/eSn, SSt (Stainless Steel), St/eCu
Can be connected in concrete with	Cu, Cu/eSn, SSt (Stainless Steel), St/eCu, St/tZn
Tightening torque	9 Nm

#### Testing as per IEC EN 62561

The component has successfully passed the testing requirements of standard IEC EN 62561-1 "Lightning protection system components (LPSC) – Part 1 : Requirements for connection components".  
Test report No **30748** by accredited laboratory as per ISO 17025

#### Manufacturing Quality Control

Manufacturing quality control according standard ISO 9001

#### Country of Origin

Greece

**Unit: piece / Package: 25 pieces**

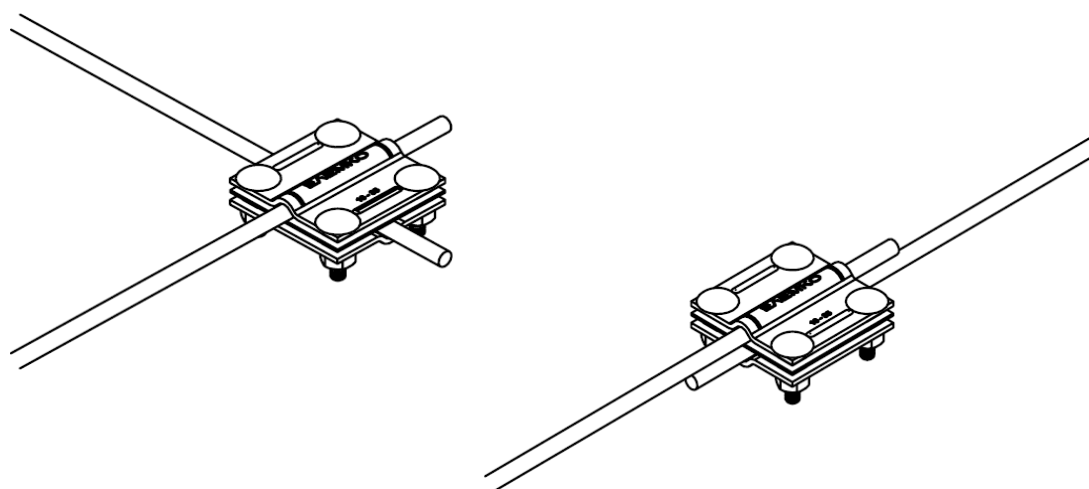

We reserve the right to introduce changes in the component due to technical evolution.