

PRODUCT DATA SHEET

LIGHTNING PROTECTION AND EARTHING SYSTEM COMPONENTS

Code: 64 20 252 (copper) / 64 22 252 (tin plated copper)

Description: 25x2mm tape conductor

ed.02/2021

Application

Copper or tin plated copper tape used as air termination conductor, down conductor and earth conductor.

Technical characteristics

Width	25 mm
Thickness	2 mm
Cross sectional area	50 mm ²
Material	Copper (Cu) or tin plated copper (Cu/eSn)
Electrical resistivity	≤0,018 μΩm
Tensile strength	200 – 450 N/mm ²

Installation instructions

Installation	Above ground, buried in ground, embedded in concrete
Can be connected above ground with	Cu, Cu-A (copper alloy), Cu/eSn, Stainless Steel (SSt), St/eCu
Can be connected buried in ground with	Cu, Cu-A (copper alloy), Cu/eSn, Stainless Steel (SSt), St/eCu
Can be connected in concrete with	Cu, Cu-A (copper alloy), Cu/eSn, Stainless Steel (SSt), St/eCu, St/tZn



Comply with

The component complies with standard IEC EN 62561-2 "Lightning protection system components (LPSC) – Part 2 : Requirements for conductors and earth electrodes".

Manufacturing Quality Control

Manufacturing quality control according standard ISO 9001

Country of Origin

Greece

Needed accessories¹⁾

Clamps (e.g. 6221833), fasteners (e.g. 6103025, 6121200) for the spacing consult fasteners' installation instructions.

Unit: meter / Package: 40 m approx. / 0,450 kg/m

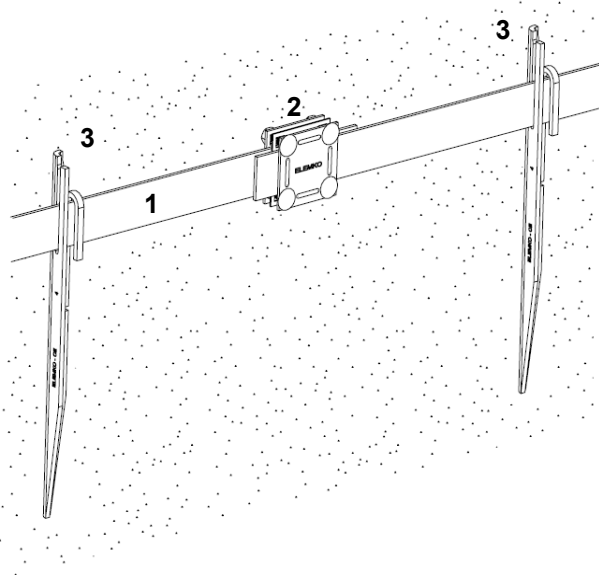

1. Tape conductor
2. Clamp (not included)
3. Earth electrode fastener (not included)
4. Fastener (not included)

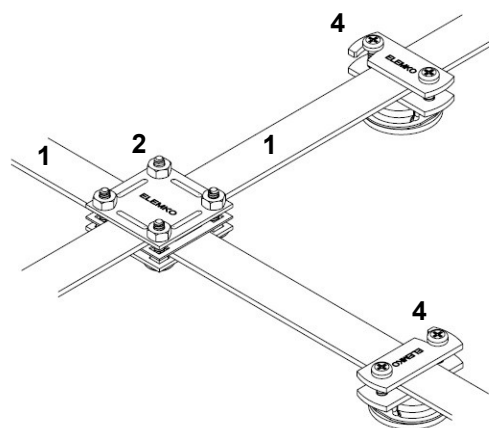

Typical applications of the conductor

¹⁾ See relevant data sheets

We reserve the right to introduce changes in the component due to technical evolution.