

PRODUCT DATA SHEET

LIGHTNING PROTECTION AND EARTHING SYSTEM COMPONENTS

Code: 64 60 010

Description: Ø10mm stainless steel solid round conductor

ed.02/2021

Application

Stainless steel conductor (grade V2A) used as air termination conductor, down conductor and earth electrode.

Technical characteristics

Diameter	10 mm
Cross sectional area	78 mm ²
Material	Stainless steel (SSt/V2A)
Electrical resistivity	<0,80 μΩm
Tensile strength	350 – 770 N/mm ²



Installation instructions

Installation	Above ground, buried in ground (unsuitable for anaerobic soils, such as clayey ones etc), embedded in concrete
Can be connected above ground with	Al, Cu, Cu-A (copper alloy), Cu/eSn, Stainless Steel (SSt), St/eCu, St/tZn
Can be connected buried in ground with	Cu, Cu-A (copper alloy), Cu/eSn, Stainless Steel (SSt), St/eCu, St/tZn (St/tZn not simultaneously with Cu, Cu/eSn & St/eCu)
Can be connected in concrete with	Cu, Cu-A (copper alloy), Cu/eSn, Stainless Steel (SSt), St/eCu, St/tZn
Straightening	For straightening can be used straightener, ELEMKO code 6900100

Testing as per IEC EN 62561

The component has successfully passed the testing requirements of standard IEC EN 62561-2 "Lightning protection system components (LPSC) – Part 2 : Requirements for conductors and earth electrodes".
Test report **No 31093** by accredited laboratory as per ISO 17025

Manufacturing Quality Control

Manufacturing quality control according standard ISO 9001

Country of Origin

Greece

Needed accessories¹⁾

Clamps (e.g. 6261810), fasteners (e.g. 6161100, 6130104) for the spacing consult fasteners' installation instructions

Unit: meter / Package: 50 m approx. / 0,610 kg/m

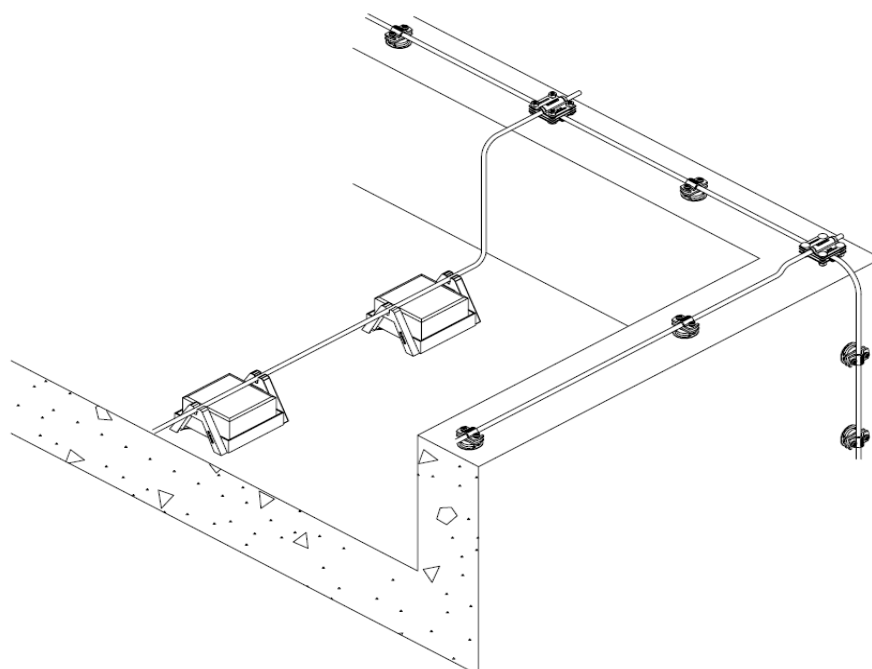

¹⁾ See relevant data sheet

We reserve the right to introduce changes in the component due to technical evolution.