

PRODUCT DATA SHEET

LIGHTNING PROTECTION AND EARTHING SYSTEM COMPONENTS

Code: 61 43 100
ed.02/2021
Description: Al air terminal rod base

Application

Base for mounting air termination rods on horizontal surfaces.

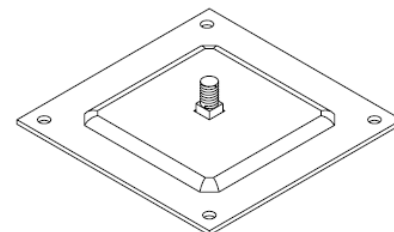

Technical characteristics

Material	Aluminium (Al)
Dimensions	100x100 mm
Thread to be mounted the air terminal	M8

Installation instructions

Installation	Outdoor
Can be connected with	Al, SSt (Stainless Steel), St/tZn
Fixing	Suitable for air termination rods up to 16 mm diameter and 1000 mm length, to be mounted on horizontal surfaces. Its fixing to the surface is achieved through four wood fixing screws and four PVC wall plugs (not included).
Tightening torque	13 Nm (M8 screw)

Manufacturing Quality Control

Manufacturing quality control according standard ISO 9001

Country of Origin

Greece

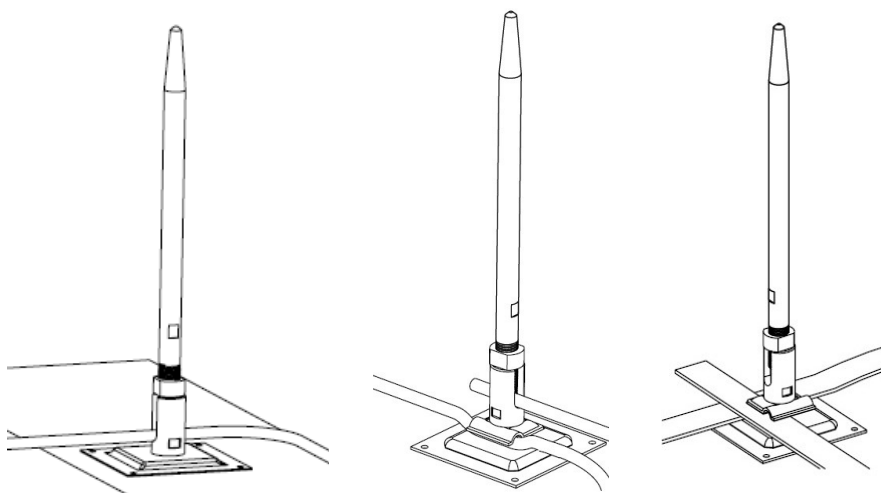
Unit: piece / Package: 1 piece

Typical example of component's use (rod & conductor are not included)

We reserve the right to introduce changes in the component due to technical evolution.