

1 2 3 4 5 6

A

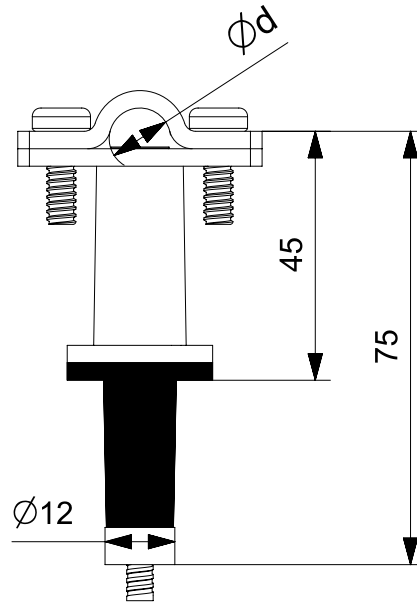
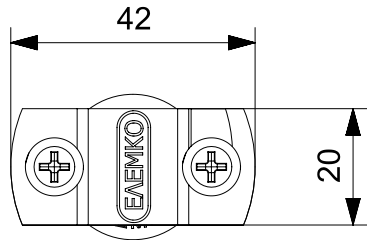

Description

Conductor fastener, tested according to IEC EN 62561-4, for use in air termination system. Suitable for fastening solid round or stranded conductor Ø8–10 mm (50–70 mm²) on tile or eternite roofs. The fastener consists of :

- A part which tightens the conductor.
- A polyamid support suitable for external installation and resistant to ultraviolet radiation.
- A soft PVC expansion plug for the fixation on the tile.

The conductor's tightening is achieved by two stainless steel (V2A) screws M6x16 mm.

A

B

B

C

C

Typical application

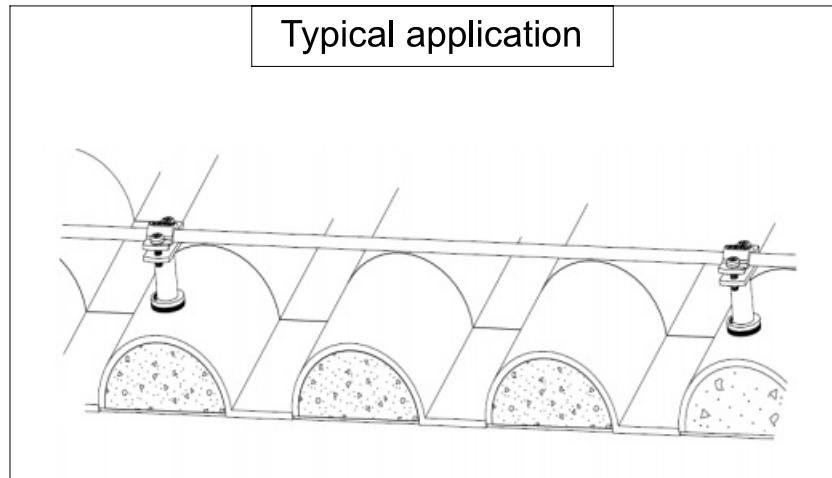

Description	Raw material	Ød	Item code	Optional conductor (Round)
Conductor's fastener	St/tZn	8-10	61 02 121	64 00 108
Conductor's fastener	Cu	8-10	61 22 121	64 20 008



Title:
Conductor fastener on tiles or eternite roofs

FIRST ISSUED	June 2016
DRAWN BY	Dionysopoulos G.
CHECKED BY	Kokkinos N.
APPROVED BY	Kokkinos N.
SCALE	None
ISSUANCE DATE	July 2021

Model
61 x2 121
www.elemko.gr elemko@elemko.gr

All dimensions in mm

1 2 3 4 5 A4

D