

## PRODUCT DATA SHEET

### LIGHTNING PROTECTION AND EARTHING SYSTEM COMPONENTS

**Code: 61 41 100**

ed.02/2021

**Description: Ø8–10 mm aluminium conductor fastener**

Page 1 of 2

#### Application

Fastening round or stranded conductor. Used in air termination system, down conductor system. Suitable for brick or concrete surfaces.

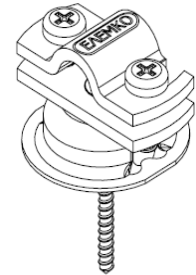

#### Classification as per IEC EN 62561

- Metallic.
- With screws.
- Designed to clamp but allow axial movement of the conductor.

#### Technical characteristics

Material	Conductor fastener: aluminium (Al) Spacer: Stainless steel (SSt)
Screws	M6x16 mm, V2A stainless steel screws One stainless steel wood fixing screw
Withstands (according to IEC EN 62561-4)	Lateral load, 200 N Axial load, 50 N

#### Installation instructions

Conductor's dimensions	Ø8–10 mm (50–70 mm <sup>2</sup> )
Compatibility with conductors made of	Al, SSt (Stainless Steel), St/tZn
Tightening torque of conductor	3,5Nm
Fixing on brick or concrete	Through a wood fixing screw (included) and a PVC wall plug Ø8 mm (not included)
Spacing between fasteners of air termination conductors	≤1000 mm for solid conductor <sup>1)</sup> . ≤500 mm for stranded conductor <sup>1)</sup> .
Spacing between fasteners of down conductors	≤1000 mm for solid conductor. ≤1000 mm for stranded conductor used for heights ≤20 m. ≤500 mm for stranded conductor for heights ≥20 m.
Before and after of change of direction or clamp or contraction-expansion absorbing component.	≤300 mm.

#### Testing as per IEC EN 62561

The component has successfully passed the testing requirements of standard IEC EN 62561-4 "Lightning protection system components (LPSC) – Part 4 : Requirements for conductor fasteners".  
Test report No **31108** by accredited laboratory as per ISO 17025

#### Manufacturing Quality Control

Manufacturing quality control according standard ISO 9001

#### Country of Origin

Greece

#### Optional accessories<sup>2)</sup>

PVC sealing washer, ELEMKO code 61 03 201

#### Unit: piece / Package: 50 pieces

See below typical application of the fastener

<sup>1)</sup> Where additional mechanical strength is required, e.g snow, strong winds etc, the spacing between the fasteners should be ≤300 mm.

<sup>2)</sup> See relevant data sheet

We reserve the right to introduce changes in the component due to technical evolution.

**PRODUCT DATA SHEET****LIGHTNING PROTECTION AND EARTHING SYSTEM COMPONENTS****Code: 61 41 100**

ed.02/2021

**Description: Ø8-10 mm aluminium conductor fastener**

Page 2 of 2

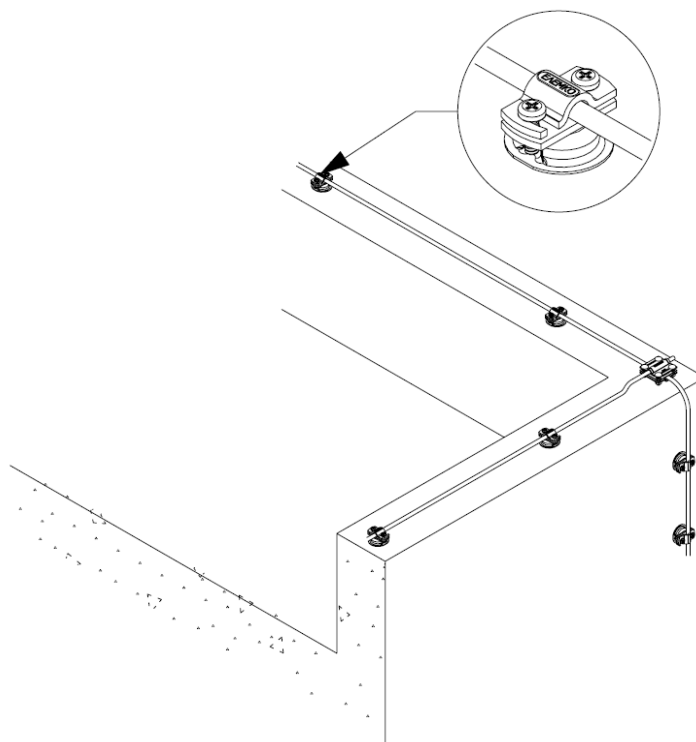

Typical application of the fastener