

PRODUCT DATA SHEET

LIGHTNING PROTECTION AND EARTHING SYSTEM COMPONENTS

Code: 64 20 505

Description: 50x5mm copper tape conductor

ed.02/2021

Application

Copper tape used as earth conductor, internal ring bonding conductor and earth electrode.

Technical characteristics

Width	50 mm
Thickness	5 mm
Cross sectional area	250 mm ²
Material	Copper (Cu)
Electrical resistivity	≤0,018 μΩm
Tensile strength	200 – 450 N/mm ²



Installation instructions

Installation	Above ground, buried in ground, embedded in concrete
Can be connected above ground with	Cu, Cu-A (copper alloy), Cu/eSn, Stainless Steel (SSt), St/eCu
Can be connected buried in ground with	Cu, Cu-A (copper alloy), Cu/eSn, Stainless Steel (SSt), St/eCu
Can be connected in concrete with	Cu, Cu-A (copper alloy), Cu/eSn, Stainless Steel (SSt), St/eCu, St/tZn

Comply with

The component complies with standard IEC EN 62561-2 "Lightning protection system components (LPSC) – Part 2 : Requirements for conductors and earth electrodes".

Manufacturing Quality Control

Manufacturing quality control according standard ISO 9001

Country of Origin

Greece

Needed accessories¹⁾

Clamps (e.g. 6224060), fasteners (e.g 6123005) for the spacing consult fasteners' installation instructions.

Unit: meter / 1,780 kg/m

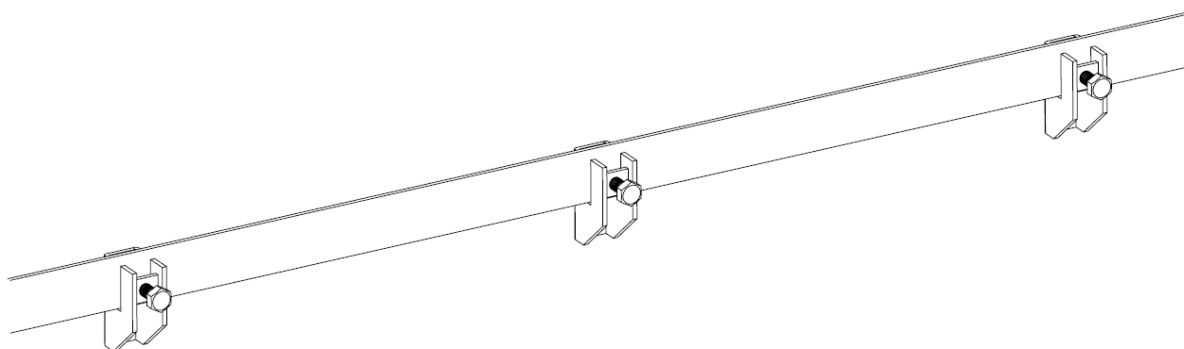

¹⁾ See relevant data sheets

We reserve the right to introduce changes in the component due to technical evolution.